

GG TRIO - Technical Rider

NOTE*) GG Trio is mostly booked as a (semi-)acoustic walk-act but sometimes perform on stage.

Ch.	Signal	Source	comments
1	Percussion	DI.+out	Feet percussion (snare)
2	Acoustic Guitar	DI.+out	Wireless system (E-band)
3	Double Bass	DI.+out	
4	Bluesharp	SM 57	
5	Vocals Guitar	SM 58	Lead vocals
6	Vocals Double Bass	SM 58	Backing vocals
7	Vocals Bluesharp	SM 58	Lead vocals

Frans
Frank
Gerd

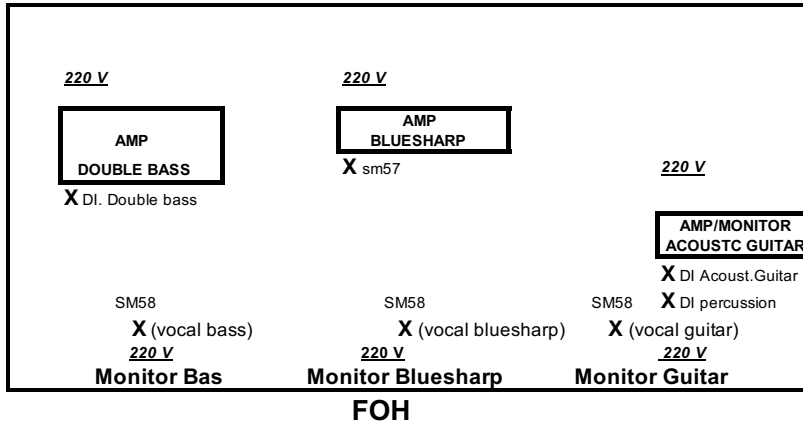

Lissen to audio on www.ggtrio.com

GG TRIO - Technical Rider

Dear organizer and colleague technology

For a smooth course of business, we (sometimes) expect the following technical preparations from you.

FOH:

- a professional 16/4/2-Mixing desk with at least 1 Aux-Sends (Post Fader) en 3 Monitor-Sends (Pre-Fader), 4-Band-EQ with parametric control for mid-high and mid-low on each channel.
- 5 Free accessible EQs 2 for L+R FOH and 3 for the separate monitorchannels.
- 1 Stereo-Multi effect (SPX, LXP) for reverb (0,8 to 1 sec. please)
- 1 Talkback-Microfoon

Microphones & Stands:

- 1x Bluesharp-amp.microphone (SM57) (or without the amp Harmonica also plays on a SM57)
- 3x Vocal microphones (SM58).
- 3x DI's for akoestisch gitaar, double bass and feet percussion (snare).
- Enough XLR-cables and Microphonestands

PA / Monitoring:

- Professional 3-Way PA System with sufficient power (JBL, GAE, D&B)
- 3 independent Monitorchannels from the FOH with 3x 12/2"-Wedges from at least 600 W.

Power:

- 6 free punch-in points (230V/16A) see the places 220V on the drawing above.
- FOH-, Stage- en Lightpower must be separated and meet current standards.

Stage:

- A broom clean and firmly bolted stage of at least 3x4 meter. The right height for the audience in the back.
- What a stage should look like is dependent on a situation. Feel free to contact us with any situation.
- For Open-Air performances, the stage and technical facilities must be covered, independent of the weather conditions.

Stagelight:

Enough stagelight for the public and for the musicians to read. Not to much running lights or smoke please.

Building-up:

Please have sound and light technician installed and ready to start when the band arrives.

Until the end of the concert, a sound technician and a house technician (for electrics) must be present.

The band doesn't bring any technicians themselves.

Wireless:

Frequency of wireless system of acoustic guitar are mostly between 863.100 and 864.99 MHz

Feel free to contact us inadvance if you have any questions:

We hope to work together in good harmony.

Technical contact GG-Trio: T: 0031 (0) 622 919 022Frans

E: info@ggtrio.nl

W: www@ggtrio.com